



FIRERAY

REFLECTIVE BEAM SMOKE DETECTOR

FEATURES

- Single Compact Housing
- 50 metre or 100 metre Version Available
- 12-24 Vdc Operation
- Low Current Consumption
- Robust Construction
- Conforms to:
BS 5839 Part 5
EN54 Part 12, UL and Vds

GENERAL DESCRIPTION

The system comprises of a single unit incorporating an infra- red Transmitter and Receiver. The signal is reflected by a prism and analysed for smoke presence. Should a predetermined level be reached, a fire condition is activated.

The system is designed to be mounted so that the beam will project between 0.3 and 0.6 metres below and parallel to the ceiling. Lateral detection may be up to 7.5 metres either side of the beam.

APPLICATIONS

Atriums Shopping Malls, Heritage Sites, Churches, Museums, Leisure Centres, Open Plan Offices, Warehouses, Factories, Power Stations etc.



Fire Fighting Enterprises

CE



Number FM01794
BS EN ISO 9001

REFLECTIVE BEAM SMOKE DETECTOR

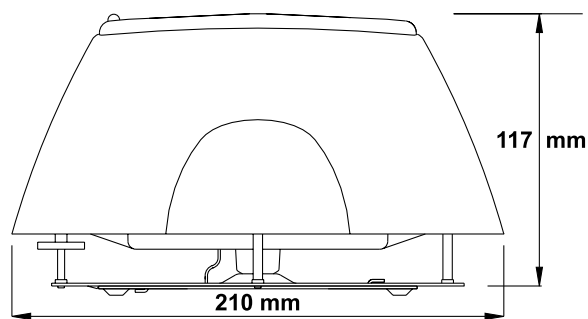

TECHNICAL SPECIFICATION

CONSTRUCTION

Housing: Flame Retardent ABS
Rating: IP50
Finish: Grey/Black
Weight: Approx. 0.7 Kg
Dimensions: 210 x 117 x 120

ELECTRICAL

Input Voltage: 12-24Vdc
Quiescent Current: 4mA @ 24Vdc
Alarm Current: 14mA
Output: Fire - c/o contacts. (2 amp @ 30Vdc)
Fault - c/o contacts. (2 amp @ 30Vdc)
Temperature Range: -30°C to +55°C

FEATURES

Latching / Non Latching Alarm
Reflector Targeting Mode
Integral Alignment Aid
Microprocessor Controlled
Automatic Contamination Compensation
Selectable Sensitivity

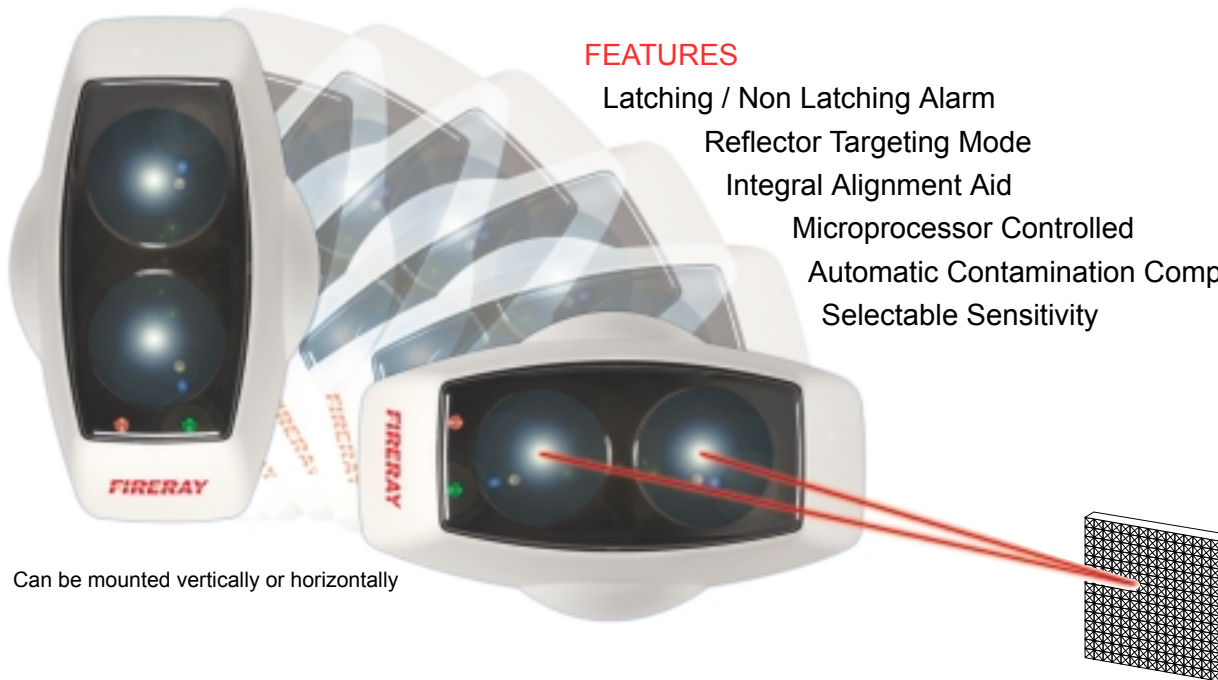

DESIGNED TO BRITISH STANDARD BS5839 PART5 & EN54 Part12

In the interest of improving quality and design, we reserve the right to amend specifications without prior notice.



Fire Fighting Enterprises

A
HALMA GROUP
COMPANY

5 Wedgwood Court, Wedgwood Way, Stevenage, Hertfordshire, England SG1 4QR
Telephone: 44 (0) 1438 317216 Facsimile: 44 (0) 1438 722136 e-mail: sales@ffeuk.com website: www.ffeuk.com