



Main Features

- ◆ CT technology apply in liquid check, attain the liquid property via Computed tomography scan
- ◆ Detect and differentiate water, milk, alcohol, gas, lacquer thinner, sulphuric acid and the other normal liquid with their dangerous levels of: Safe, Suspect and Danger
- ◆ Video image and CT image of detected object for analysing and tracing
- ◆ Detect the liquid in glass, plastic, metal, ceramics and the other normal packing material
- ◆ High speed detecting, maximum 20sec per liquid object
- ◆ Power on / running self-diagnostics function
- ◆ Comply with liquid scanner requirements in DB11/646.6-2009
- ◆ Wheel with lock, for easy moving and fixing
- ◆ Varieties analysis reports

EI-LS1525 X-Ray Liquid Security Inspection Equipment

Main technical parameters

- ◆ Object Size.....150mm(diameter)×250mm(height)
- ◆ Detecting speed.....180 pc/hour
- ◆ X-ray generator.....80 KV combination
- ◆ Cooling/ Duty cycle.....Sealed oil cooling 100%
- ◆ X-ray detection sensor.....Precision photodiode array
- ◆ Leakage.....≤1 μGy/hour(5cm from the cover)
- ◆ Beam direction.....horizontal irradiation
- ◆ Noise<60dB(A)
- ◆ Dimension.....1050(L)×720(W)×1205(H)mm
- ◆ Weight.....350KG
- ◆ Work temperature & humidity.....0°C~45°C / 20%~95% (non-condensing)
- ◆ Storage temperature & humidity.....-40°C~60°C / 20%~95% (non-condensing)
- ◆ Voltage.....AC 220 V +10% ~ -15%,110V is acceptable under special requirements
- ◆ Frequency.....50±3Hz, 60±3Hz is acceptable under special requirements
- ◆ Consumption.....0.5KVA

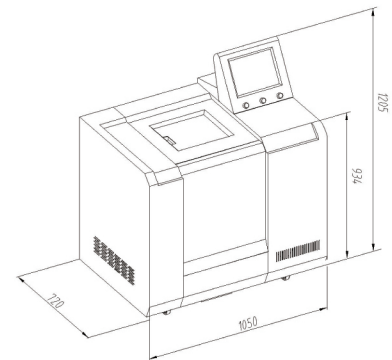

Information Bar

WSF
ISO9001
Certification registration No:
03812Q20382ROM

WSF
ISO14001
Certification registration No:
03812E20383R2M

WSF
O H S M S
Certification registration No:
03811S10213ROM



Shanghai Eastimage Equipment Co., Ltd.
Address: No.111, Zhiye Road, Pudong New District,
Shanghai, P.R. China
Postcode: 201200
Tel: +86 21 33909300
Fax: +86 21 58545890
E-mail: chinaeastimage@eastimage.com.cn
Http: //www.eastimage.com.cn